

CONTRACT NO: 009902 FEDERAL AID NO: ARPA001
CONTRACT TITLE: SR 16 / SR 160 / KITSAP COUNTY, FISH PAS REMOVE FI
CHANGE ORDER NO: 4 R3 TEMP ROADWAY REVISION

PRIME CONTRACTOR: [REDACTED] CECCANTI, INC.
4116 BROOKDALE RD E
TACOMA WA 98446-1613

(X) Ordered by Engineer under the terms of Section 1-04.4 of the Standard Specifications
() Change proposed by Contractor

<p>ENDORSED BY:</p> <p><i>Signature on file</i></p> <hr/> <p>CONTRACTOR SIGNATURE</p> <p>Mar 28, 2024</p> <hr/> <p>DATE</p>	<p>SURETY CONSENT:</p> <hr/> <p>ATTORNEY IN FACT</p> <hr/> <p>DATE</p>
--	--

ORIGINAL CONTRACT AMOUNT: 33,625,114.00
CURRENT CONTRACT AMOUNT: 33,614,429.00
ESTIMATED NET CHANGE THIS ORDER: 1,054,854.00
ESTIMATED CONTRACT TOTAL AFTER CHANGE: 34,669,283.00

Signature Required: (X) Project Engineer (X) State Construction Engineer
(X) Regional Administrator () Other Agency

<p><i>Signature on file</i></p> <hr/> <p>PROJECT ENGINEER SIGNATURE</p> <p>Mar 28, 2024</p> <hr/> <p>DATE</p>	<p><i>Signature on file</i></p> <p><small>Jon Deff</small></p> <hr/> <p>STATE CONSTRUCTION ENGINEER SIGNATURE</p> <p>Apr 5, 2024</p> <hr/> <p>DATE</p>
<p><i>Signature on file</i></p> <p><small>Brian Whitehouse (Mar 28, 2024 07:51 PDT)</small></p> <hr/> <p>REGIONAL ADMINISTRATOR SIGNATURE</p> <p>Mar 28, 2024</p> <hr/> <p>DATE</p>	<p>OTHER APPROVAL WHEN REQUIRED</p> <hr/> <p>SIGNATURE DATE</p> <hr/> <p>REPRESENTING</p>

CONTRACT NO: 009902

CHANGE ORDER NO: 4 R3

All work, materials, and measurements to be in accordance with the provisions of the Standard Specifications and Special Provisions for the type of construction involved.

This contract is revised as follows:

Description:

This change revises the TOEB line roadway cross sections and revises the quantities for both the TOEB and TOWB lines. The Work requires unsuitable excavation including haul, additional select borrow incl. haul, additional quarry spalls, and construction geotextile for separation for the construction of the temporary eastbound roadway (TOEB line).

Materials:

Additional Select Borrow shall conform to the requirements of Section 9-03.14(2) and will be accepted by visual acceptance.

Additional Quarry Spalls shall conform to the requirements of 9-13 and will be accepted by visual acceptance.

Construction Geotextile for Separation shall conform to the requirements of Section 2-12.2 and will be accepted by visual acceptance.

Construction Requirements:

The Contractor shall construct the TOEB temporary roadway in accordance with pages 5 to 9 of this change order and as staked by the Engineer.

The Contractor shall remove unsuitable foundation material to the limits established by the Engineer. As shown on pages 8 to 9 of this change order, the excavated area shall be backfilled with 2' of quarry spalls and select borrow up to the planned subgrade elevation where not accounted for in the item "Earthwork Site Blackjack".

Unsuitable excavation incl. haul shall not exceed 3 feet in depth and shall conform to the requirements of Section 2-03.3(14)E.

Additional Select Borrow Incl. Haul shall be furnished and installed in accordance with Section 2-03.3.

Additional Quarry Spalls shall be furnished and installed in accordance with Section 8-15.3(6).

Construction Geotextile for Separation shall be furnished and installed in accordance with Section 2-12.3.

Measurement:

Unsuitable Foundation Excavation Incl. Haul will be measured by the square yard. Unsuitable Foundation excavation includes approximately 4,250 tons of Select Borrow.

CO#4 Addl Quarry Spalls will be measured by the ton.

CO#4 Construction Geotextile For Separation will be measured by the square yard for the ground surface area actually covered.

Payment:

"CO#4 Unsuitable Foundation Excavation Incl. Haul", per square yard, shall be full compensation for all costs incurred for excavating, loading, hauling, and disposing of unsuitable foundation material, and for furnishing and placing additional Select Borrow to backfill the excavation area to the planned subgrade elevation for areas which are not incidental to the existing contract item "Earthwork Site Blackjack"

"CO#4 Addl Quarry Spalls", per ton, shall be full pay for all costs in furnishing, placing, and compacting spalls.

WASHINGTON STATE
DEPARTMENT OF TRANSPORTATION
CHANGE ORDER

DATE:03/27/24
PAGE 3 of 9

CONTRACT NO:009902

CHANGE ORDER NO: 4 R3

"CO#4 Construction Geotextile For Separation", per square yard, shall be full pay for all costs to furnish and install Construction Geotextile For Separation as described above.

Contract Time:

No extension of time will be granted as a result of this change.

WASHINGTON STATE
DEPARTMENT OF TRANSPORTATION
CHANGE ORDER

DATE: 03/27/24
PAGE 4 of 9

CONTRACT NO: 009902	CHANGE ORDER NO: 4 R3
---------------------	-----------------------

ITEM NO	GROUP NO	STD ITEM	UNIT OF MEASURE	UNIT PRICE	EST QTY CHANGE	EST AMT CHANGE
1003	01		S.Y.	59.39	8,600.00	510,754.00
ITEM DESCRIPTION: CO#4 UNSUITABLE FOUNDATION EXCAVATION INC						
1004	01		TON	7,610.00	67.00	509,870.00
ITEM DESCRIPTION: CO#4 ADDL QUARRY SPALLS						
1005	01		S.Y.	3.50	9,780.00	34,230.00
ITEM DESCRIPTION: CO#4 CONSTRUCTION GEOTEXTILE FOR SEPARATI						
						AMOUNT TOTAL

						1,054,854.00
						=====

CONTRACT 009902

DISTRICT 3

CHANGE ORDER NUMBER 004

TYPE OF CHANGE ORDER CONSTRUCTION

DATED 04-08-2024

TIME 12:00:58

ITEM	GROUP	STD ITEM	UNIT OF MEAS	UNIT PRICE	QUANTITY CHANGE	AMOUNT CHANGE
185	01		S.Y.	\$59.3900	8,600.00	\$510,754.00
CCIS TEMP ITEM NUMBER: 1003						
DESC...: CO#4 UNSUITABLE FOUNDATION EXCAVATION INC						
186	01		TON	\$7,610.0000	67.00	\$509,870.00
CCIS TEMP ITEM NUMBER: 1004						
DESC...: CO#4 ADDL QUARRY SPALLS						
187	01		S.Y.	\$3.5000	9,780.00	\$3,423,000.00
CCIS TEMP ITEM NUMBER: 1005						
187	01		S.Y.	\$3.5000	.00	\$3,388,770.00-
CCIS TEMP ITEM NUMBER: 1005						
DESC...: CO#4 CONSTRUCTION GEOTEXTILE FOR SEPARATI						
TOTAL NET CHANGE						\$1,054,854.00

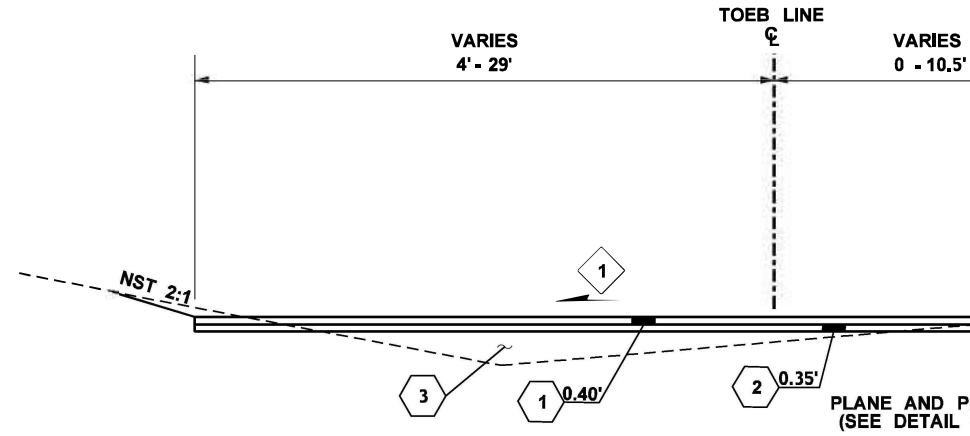

TEMP. ROADWAY SECTION

TOEB 299+96 TO 309+16
~~TOEB 310+75 TO 333+80~~

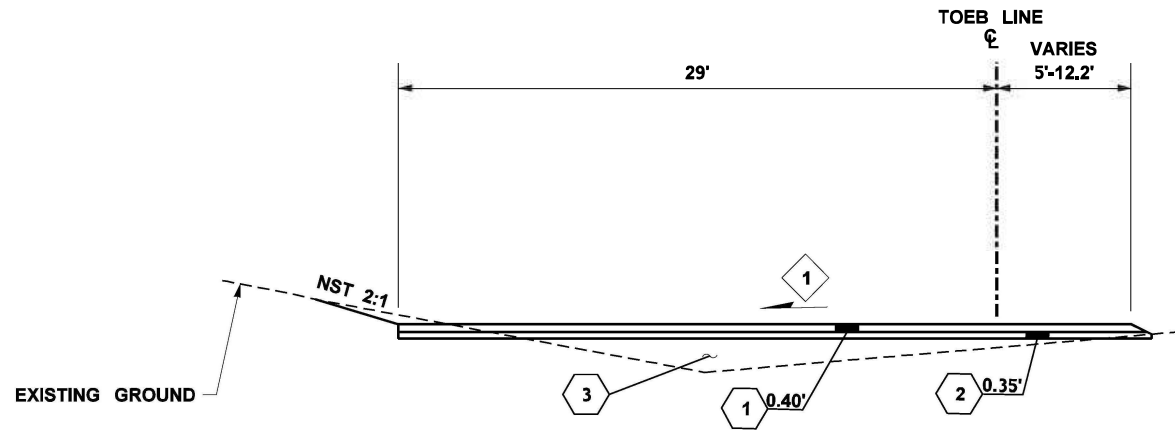

TEMP. ROADWAY SECTION

TOEB 309+16 TO ~~318+75~~ 310+50

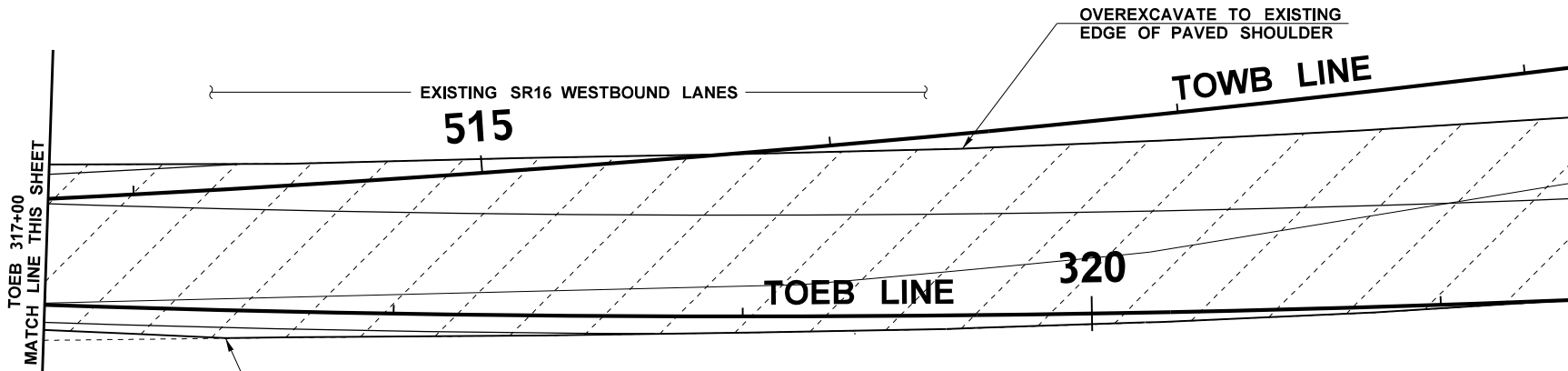
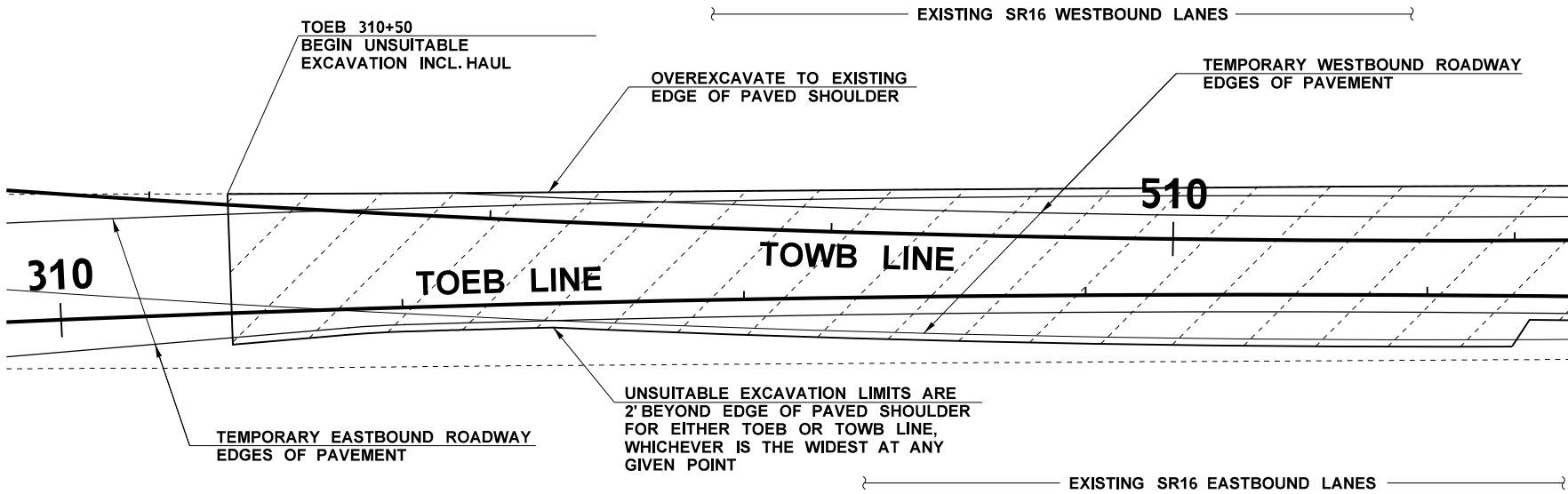

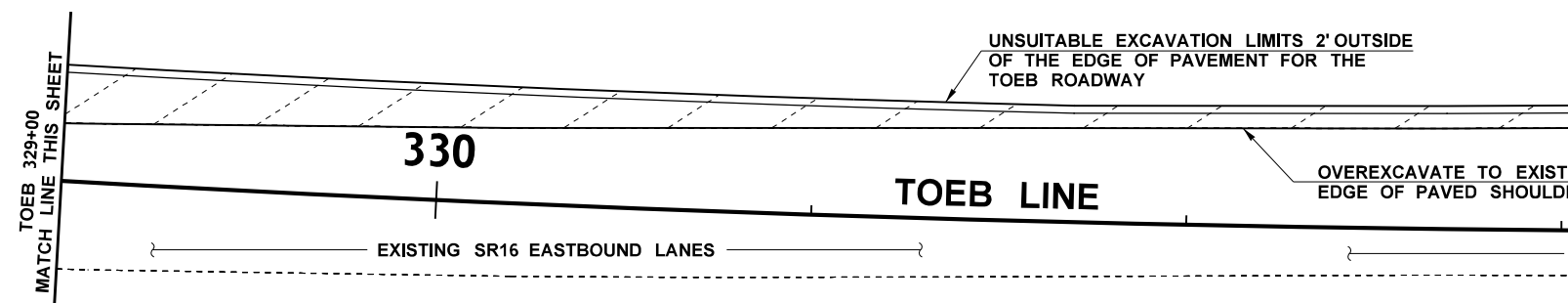
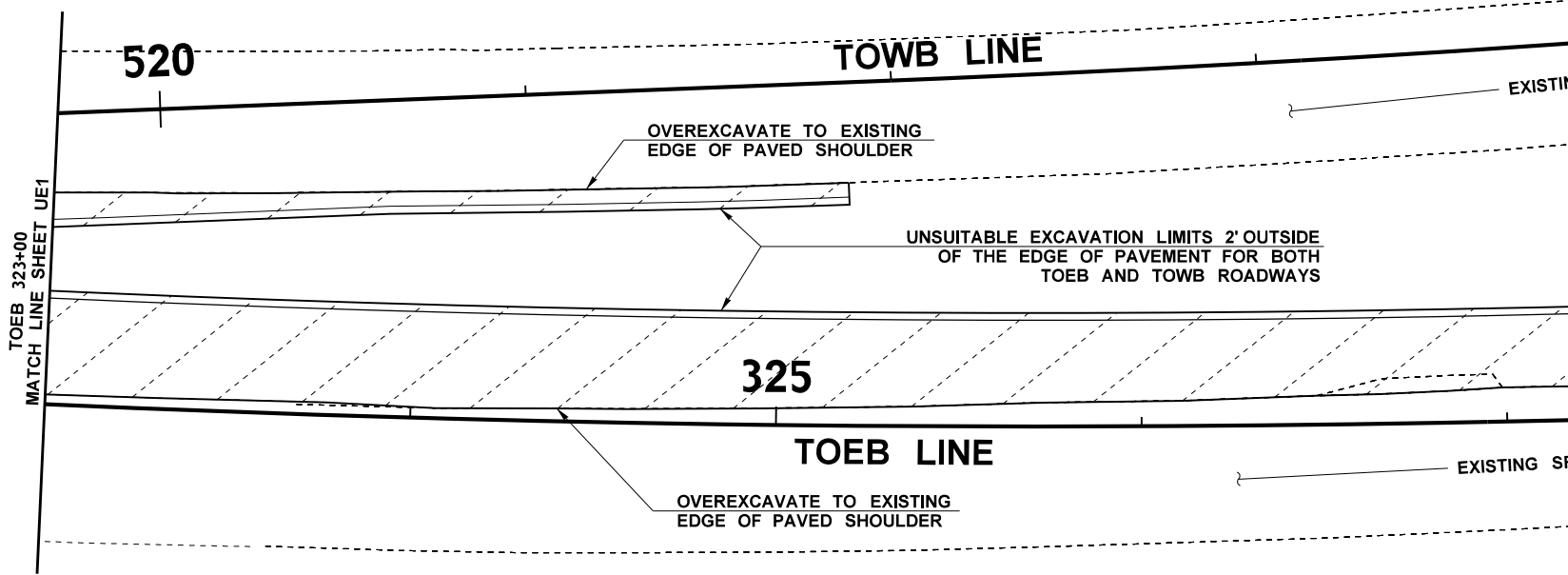

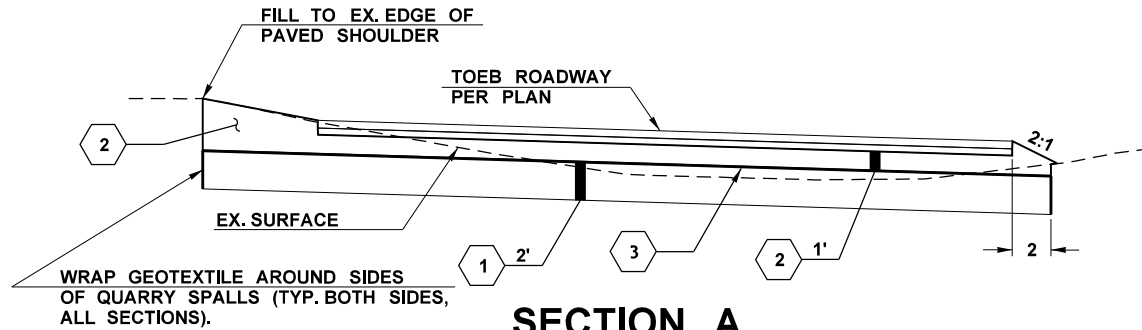

WRAP GEOTEXTILE AROUND SIDES OF QUARRY SPALLS (TYP. BOTH SIDES, ALL SECTIONS).

SECTION A
TOEB 310+50 TO 311+40

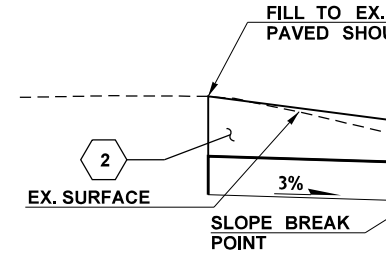
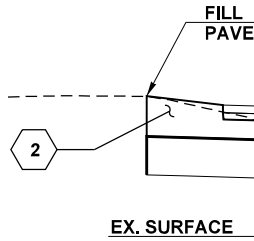

TOEB SUPERELEVATION CHANGE BETWEEN 315+02 AND 316+68. MAINTAIN CROSS-SLOPE AS SHOWN 2' FROM EDGE OF SHOULDER TO TOEB ROADWAY.

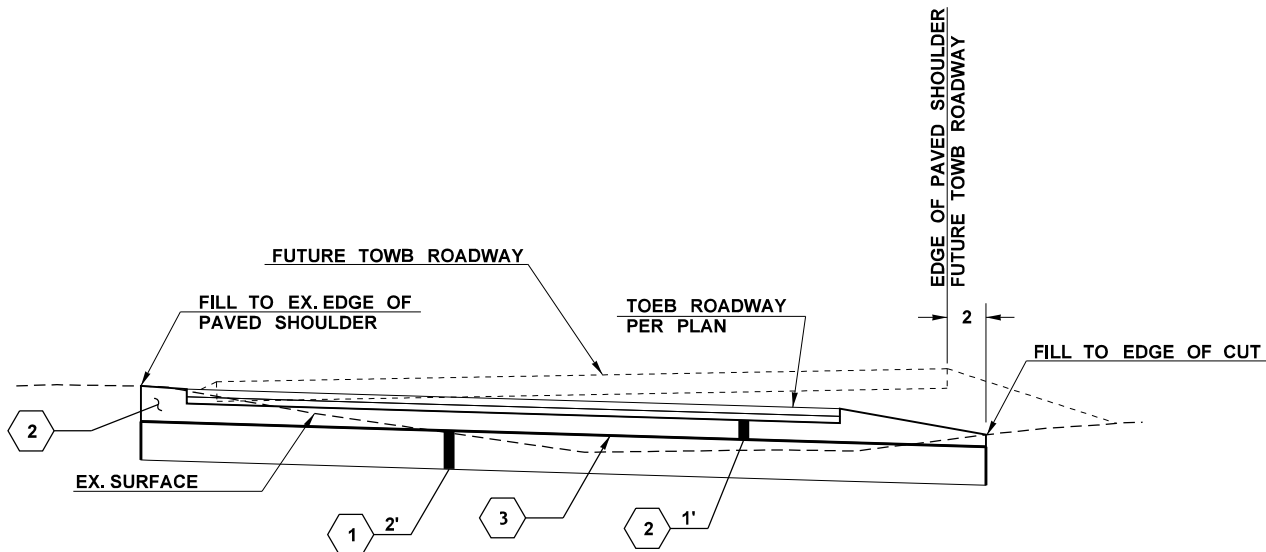

SECTION B
TOEB 311+40 TO 314+30

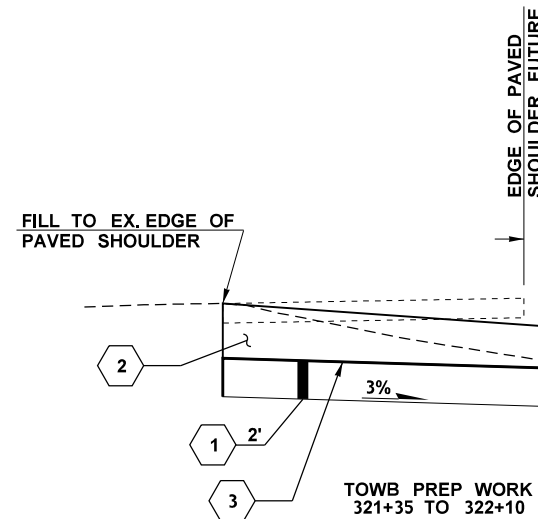

TOWB PREP WORK
321+35 TO 322+10

LEGEND

- 1 QUARRY SPALLS
- 2 SELECT BORROW INCL. HAUL

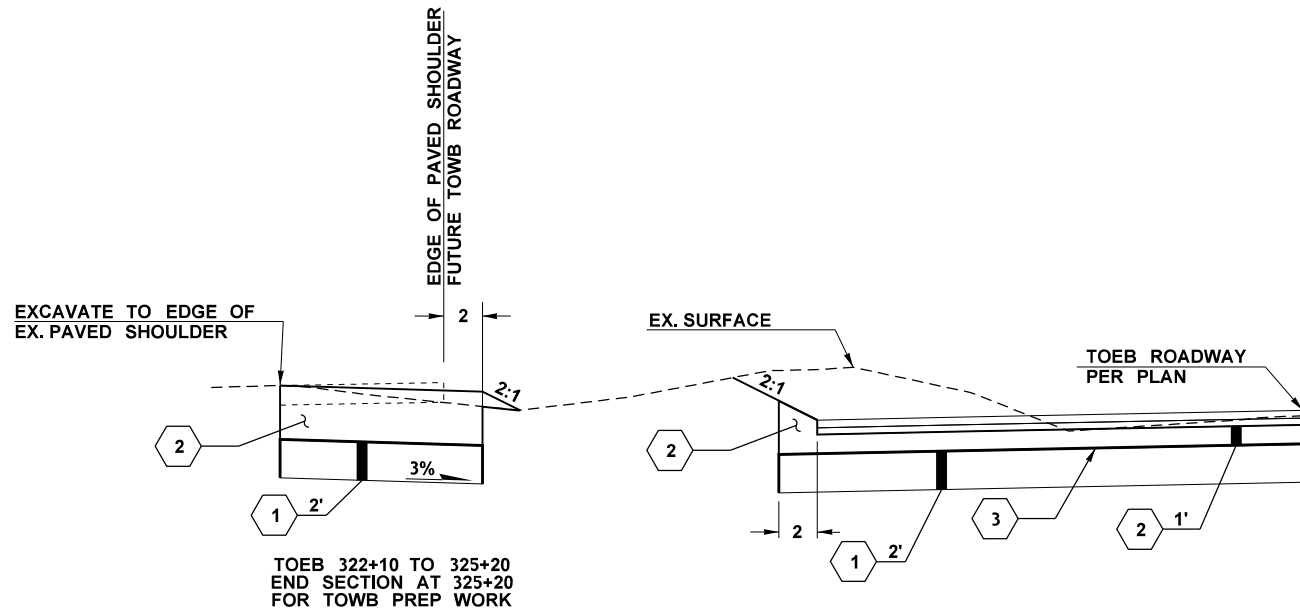

SECTION G
TOEB 322+60 TO 325+55

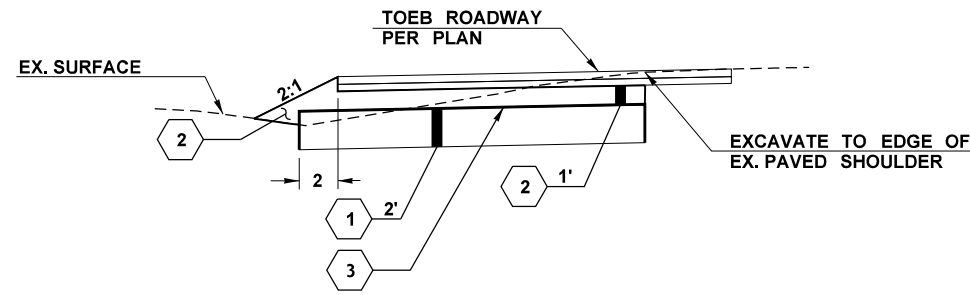

SECTION H
TOEB 325+55 TO 333+87.24

LEGEND

- 1 QUARRY SPALLS
- 2 SELECT BORROW INCL. HAUL